

SeaBat 8101

PRODUCT SPECIFICATION

MULTIBEAM ECHOSOUNDER



- Phase and amplitude bottom detection
- Circular array: all beams 1.5°
- 150° swath coverage (upgradeable to 210°)
- 240 kHz frequency
- Up to 600m swath width (with Option 040)
- Meets USACE Class 1 standards
- Meets IHO standards

The SeaBat 8101 Multibeam Echosounder measures discrete depths, enabling complex underwater features to be mapped with precision. Dense coverage is achieved utilizing up to 4,000 soundings per second for a swath up to 600 meters in width, even as the survey vessel travels at speeds in excess of 18 knots.

With high accuracy and a measurement rate of up to 40 profiles per second, the SeaBat 8101 enables surveys to be completed faster and in greater detail than previously realized. The SeaBat is an integral part of the new, integrated bathymetry surveying systems.

The SeaBat 8101 transducer is available for operating depths of 120, 300, 1500, and 3,000 meters. Small and lightweight, it can be mounted on small underwater vehicles (ROV, AUV, or towed) and transported to locations where accurate measurements are required.



RESON A/S
Denmark
Ph: + 45 47 38 00 22
Email: reson@reson.dk

RESON SA (PTY) Ltd.
South Africa
Ph: + 27 21 786 3462
Email: reson@reson.co.za

RESON Inc.
USA
Ph: + 1 805 964 6260
Email: sales@reson.com

RESON Telenav
Singapore
Ph: + 65 6 872 0863
Email: sales@telenav.com

RESON OFFSHORE Ltd.
UK
Ph: + 44 1224 709 900
Email: sales@reson.co.uk

RESON Mediterranean SRL
Italy
Ph: + 39 051 57 26 43
Email: info@reson.it

RESON GmbH
Germany
Ph: + 49 431 720 7180
Email: reson@reson-gmbh.de

RESON B.V.
The Netherlands
Ph: + 31 10 245 1500
Email: info@reson.nl

SeaBat 8101 SYSTEM SPECIFICATIONS

SYSTEM PERFORMANCE

Operating Frequency:	240 kHz
Swath Coverage:	150° (upgradeable to 210°)
Max Range:	300m 450m max range available with ER option
Number of Beams:	101, beamspacing 1.5°
Along-Track Beamwidth:	1.5° (all beams)
Across-Track Beamwidth:	1.5° (all beams)
Max. Update Rate:	40
Operational Speed:	Up to 18 knots

PROCESSOR SPECIFICATIONS

Power Required:	100/240VAC, 47/63Hz 100W maximum
Data Uplink:	High-speed digital coax with fiber-optic option
Computer Interface:	10 MB Ethernet and RS232C
Data Downlink:	Serial, 19.2k baud
Display Video Out:	SVGA; 800 x 600; Refresh Rate: ~72 Hz
Graphics Colors:	Sonar Image: 256 Colors Other Graphics: 8-bit RGB
Input Device:	3-Button Trackball
Dimensions (HWD):	177 x 483 x 417mm
Mounting:	19 in. rack mountable
Temperature:	Operating: 0° to +40°C Storage: -30° to +55°C
Weight:	20 kg (44 lbs.)

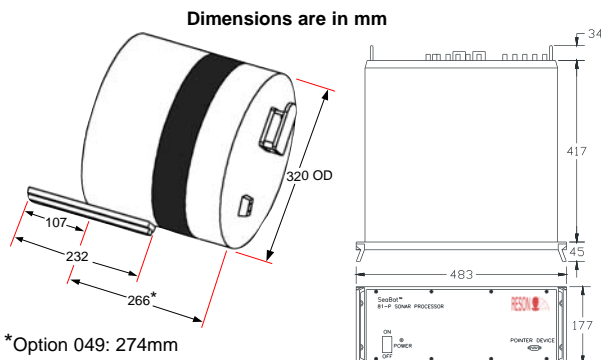

*Option 049: 274mm



DISPLAY SPECIFICATIONS

Screen Size:	14" diagonal
Display:	SVGA High-Resolution Color Monitor
Power Consumption:	80 W
Weight:	11.2 kg (24.6 lbs.)

SONAR HEAD SPECIFICATIONS

Power Requirements:	24VDC, 2 amps max. (Power available from Processor.)
Operating Depth:	120m (300,1500, and 3000m available)
Dimensions:	266 x 320mm (W / D) excluding projector
Temperature:	Operating: -5° to +40°C Storage -30° to +55°C
Weight (aluminum):	Dry: 26.8 kg (59 lbs.) Wet: 4.8 kg (10.6 lbs.)
Weight (titanium):	Dry: 40 kg (88 lbs.) Wet: 18 kg (39.6 lbs.)

RELATED PRODUCTS

- Option 033 Sidescan upgrade
- Option 034 Mounting plate assembly
- Option 035 Fairings
- Option 036 Spares kit
- Option 037 Titanium housing
- Option 038 210° swath
- Option 040 Extended-Range (ER) projector
- Option 043 Coax to fiber optic interface unit
- Option 049 Increase sonar head depth rating
- Option 051 24 VDC power supply
- Option 057 Pitch stabilization/selectable along-track beamwidth



Option 034:
Mounting Plate
Assembly

Option 035:
Hydrodynamic
Fiberglass Fairings

Version: B007 031031

©2001 RESON Inc.

Due to our policy of continuous product improvement,
RESON reserves the right change specifications without notice.